

OPERATOR'S MANUAL

547 cc OHV Vertical Shaft Engines

EnglishPage 2
Spanish (Español)Page 15
French (Français).....Page 28
Replacement PartsPage 14

Record Product Information

Before setting up and operating your new mower, please locate the model plate on the engine and record the information in the provided area to the right. You can locate the model plate by standing at the operator's position and looking at the rear, right side of the engine. This information will be necessary, should you seek technical support via our web site, Customer Support Department, or with a local authorized service dealer.

Model Number

Serial Number

⚠ WARNING

Read and follow all safety rules and instructions in this manual before attempting to operate this machine.

Failure to comply with these instructions may result in personal injury - SAVE THESE INSTRUCTIONS.

⚠ WARNING

CALIFORNIA PROPOSITION 65

Engine Exhaust, some of its constituents, and certain vehicle components contain or emit chemicals known to State of California to cause cancer and birth defects or other reproductive harm.

NOTE: This Operator's Manual covers several models. Features may vary by model. Not all features in this manual are applicable to all models and the model depicted may differ from yours.



SAFE OPERATION PRACTICES

WARNING



This symbol points out important safety instructions which, if not followed, could endanger the personal safety and/or property of yourself and others. Read and follow all instructions in this manual before attempting to operate. Failure to comply with these instructions may result in personal injury. When you see this symbol, **HEED ITS WARNING!**

DANGER

This engine was built to be operated according to the safe operation practices in this manual. As with any type of power equipment, carelessness or error on the part of the operator can result in serious injury. Failure to observe the following safety instructions could result in serious injury or death.

TRAINING

1. Read, understand and follow all warnings and instructions on the engine and the equipment, and in the operator's manuals before attempting to install and/or operate. Keep this manual in a safe place for future and regular reference and for ordering replacement parts.
2. Be familiar with all controls and their proper operation. Know how to stop the engine and disengage them quickly.
3. Never allow children under 14 years of age to operate the equipment. Children 14 and over should read and understand the warnings and instructions both on the product and in the manuals and be trained and supervised by an adult.
4. Never allow adults to operate the equipment without proper instruction.
5. Keep the area of operation clear of all persons, particularly small children and pets. Stop the engine if anyone enters the area.
3. Use only an approved fuel container.
4. Never fill containers inside a vehicle or on a truck or trailer bed with a plastic liner. Always place containers on the ground away from your vehicle before filling.
5. If possible, remove equipment from the truck or trailer and refuel it on the ground. If this is not possible, then refuel equipment on a trailer with a portable container, rather than from a fuel pump dispenser nozzle.

PREPARATION

1. Wear sturdy, rough-soled work shoes and close fitting slacks and shirts. Loose fitting clothes or jewelry can be caught in the moving parts. Never operate the equipment in bare feet or sandals.
2. Disengage all powered clutch and drive control levers on the equipment before starting the engine.
3. Never leave the engine running while unattended.
4. Never attempt to make any adjustments while the engine is running, except where specifically recommended in the operator's manual(s).
6. Keep the nozzle in contact with the rim of the fuel tank or container opening at all times until fueling is complete. Do not use a nozzle lock-open device.
7. Do not overfill fuel tank. Fill tank to full as indicated by the fuel level indicator installed inside the fuel tank to allow space for fuel expansion. On some models, a fuel level indicator may NOT be present, in this instance, fill the tank no more than 1/2 inch below the bottom of the filler neck to allow space for fuel expansion.
8. Replace fuel cap and tighten securely.
9. If fuel is spilled, wipe it off the engine and the equipment. Move equipment to another area and wait 5 minutes before starting the engine.
10. To reduce fire hazards, keep the engine and equipment free of grass, leaves or other debris build up. Clean up oil or fuel spillage and remove any fuel-soaked debris.
11. Keep fuel away from sparks, open flames, pilot lights, heat, and other ignition sources.
12. Never fuel equipment indoors because flammable vapors will accumulate in the area.
13. Extinguish all cigarettes, cigars, pipes, and other sources of ignition.
14. Check fuel line, tank, cap, and fittings frequently for cracks or leaks. Replace if necessary.

SAFE HANDLING OF GASOLINE:

To avoid personal injury or property damage, use extreme care in handling gasoline. Gasoline is extremely flammable and the vapors are explosive. Serious personal injury can occur when gasoline is spilled on yourself and/or your clothes which can ignite. Wash your skin and change clothes immediately.

1. When adding fuel, turn engine OFF and let engine cool at least 5 minutes before removing the fuel cap.
2. Fill fuel tank outdoors or in well ventilated area.

SAFE OPERATION PRACTICES

OPERATION

1. When starting the engine, make sure spark plug, muffler, and fuel cap are in place.
2. Do not crank engine with spark plug removed.
3. If fuel is spilled, wipe it off the engine and the equipment. Move equipment to another area and wait 5 minutes before starting the engine.
4. Allow engine and muffler to cool before touching.
5. Keep small children away from hot or running engines. They are unaware of the dangers and can suffer burns from the engine and muffler.
6. Remove any accumulated debris from the engine cylinder and muffler areas.
7. Operate equipment with all shields and guards in place.
8. Keep hands and feet away from rotating parts.
9. Wear sturdy, rough-soled work shoes and close-fitting slacks and shirts. Loose fitting clothes, jewelry and long hair can be caught in moving parts. Shirts and pants that cover the arms and legs and steel-toed shoes are recommended.
10. When starting the engine with the recoil starter, pull handle slowly until resistance is felt, then pull rapidly, repeat if necessary.
11. Remove all equipment engine loads before starting engine.
12. Direct coupled equipment components such as, but not limited to blades, impellers, pulleys, sprockets, etc., must be securely attached.

MAINTENANCE & STORAGE

1. Keep the engine and equipment in safe working condition.
2. Allow the engine to cool at least 5 minutes before storing equipment. Never tamper with safety devices. Check their proper operation regularly.
3. Check bolts and screws for proper tightness at frequent intervals to keep the engine and equipment in safe working condition. Visually inspect them for any damage.
4. Before cleaning, repairing or inspecting; stop the engine and make certain all moving parts have stopped. Disconnect the spark plug wire and ground it against the engine to prevent unintended starting.
5. Do not change the engine governor settings or over-speed the engine. The governor controls the maximum safe operating speed of the engine.

6. Maintain and replace safety and instruction labels as necessary.
7. Always refer to the operator's manuals for important details if the equipment is to be stored for an extended period of time.
8. If the fuel tank has to be drained, do this outdoors.
9. Observe proper disposal laws and regulations for fuel, oil, etc. to protect the environment.

DO NOT MODIFY ENGINE

To avoid serious injury or death, do not modify engine in any way. Tampering with the governor setting can lead to a runaway engine and cause it to operate at unsafe speeds. Never tamper with factory setting of engine governor.

NOTICE REGARDING EMISSIONS

Engines which are certified to comply with California and federal EPA emission regulations for SORE (Small Off Road Equipment) are certified to operate on regular unleaded gasoline, and may include the following emission control systems: Engine Modification (EM), Oxidizing Catalyst (OC), Secondary Air Injection (SAI) and Three Way Catalyst (TWC) if so equipped.

INTENDED USE:

The engine models listed on the cover of this manual are specifically designed and intended for use on designated outdoor power equipment only. The engine models listed also have been approved for use as replacement engines for products such as mowers, edgers and wheeled string trimmers. These engines are not approved for use in other applications. Engines used in non-approved applications or subjected to any modifications or misuse will void the engine warranty.

WARNING

Failure to use an engine as intended and as instructed may lead to property damage, personal injury or death.

ENGINE REPLACEMENT:

Please check your equipment specifications for important specific engine information, such as engine size (cc), type of shaft (horizontal or vertical) crank shaft dimensions, mounting bolt pattern, engine speed (rpm), oil capacity, fuel tank size, controls (throttle/choke), starting (recoil or electric), shut down capabilities, accessory wiring needs and other emission related specifications.

SAFE OPERATION PRACTICES

SPARK ARRESTOR





WARNING

Any equipment equipped with an internal combustion engine should not be used on or near any unimproved forest-covered, brush covered or grass-covered land unless the engine's exhaust system is equipped with a spark arrestor meeting applicable local or state laws (if any).

If a spark arrestor is used, it should be maintained in effective working order by the operator. In the State of California the above is required by law (Section 4442 of the California Public Resources Code). Other states may have similar laws. Federal laws apply on federal lands. A spark arrestor for the muffler is available through your nearest engine authorized service dealer or contact the service department, P.O. Box 361131 Cleveland, Ohio 44136-0019.

SAFETY SYMBOLS

This page depicts and describes safety symbols that may appear on the engine. Read, understand, and follow all warnings and instructions on the engine and equipment, along with the operator's manuals before attempting to install and/or operate.

Symbol	Description
	WARNING – READ THE OPERATOR'S MANUAL(S) Read, understand and follow all the safety rules and instructions in the manual(s) and on the equipment before attempting to operate. Failure to comply with this information may result in personal injury or death. Keep the manual(s) in a safe location for future and regular reference.
	DANGER — CARBON MONOXIDE Never run an engine indoors or in a poorly ventilated area. Engine exhaust contains carbon monoxide, an odorless and deadly gas.
	DANGER — ELECTRICAL SHOCK Do not use the engine's electric starter in the rain.
	WARNING—GASOLINE IS FLAMMABLE Allow the engine to cool at least 5 minutes before refueling.
	WARNING— AVOID BURN INJURY The muffler and engine become very hot and can cause serious burn injuries. Do not touch. Allow the equipment to cool for at least 5 minutes before storing or attempting any service.

WARNING

Your Responsibility—Restrict the use of the equipment to persons who read, understand and follow all warnings and instructions on the engine and the equipment, and in the operator's manuals. - **SAVE THESE INSTRUCTIONS!**

SET-UP

Fuel & Oil

NOTE: The engine is shipped without fuel or oil in the engine. Running the engine with insufficient oil can cause serious engine damage and void the engine warranty.

⚠ WARNING

Always keep hands and feet clear of equipment moving parts. Do not use a pressurized starting fluid. Vapors are flammable.

OIL RECOMMENDATIONS

Before starting engine, fill with motor oil, capacity is 1800 ml/57.5 oz. Refer to viscosity chart in Figure 1 for oil recommendations. Do not over-fill. Use a 4-stroke, or an equivalent high detergent, premium quality motor oil certified to meet or exceed U.S. automobile manufacturer's requirements for service classification of a minimum level SJ (higher letter ratings are acceptable such as SL and SM grades). Motor oil will display this designation on the container.

SAE 10W-30 is recommended for general, all temperature use. If single viscosity oil is used, select the appropriate viscosity for the average temperature in your area from the chart below.

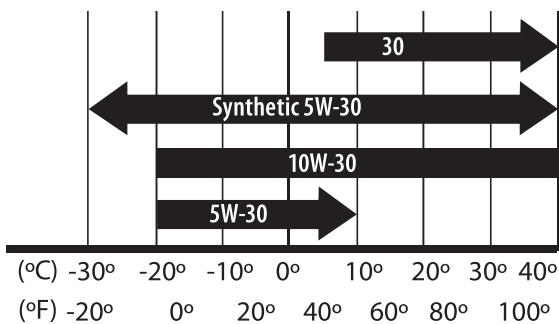

Figure 1

⚠ CAUTION

Do not use non-detergent oil or 2-stroke engine oil. It could shorten the engine's service life.

NOTE: A 5w30 synthetic oil may be used to improve start ability for cold weather (temperatures below 40 ° F).

CHECKING OIL LEVEL/ADDING OIL

IMPORTANT: Be sure to check the oil while on a level surface with the engine off.

To avoid engine damage, it is important to:

- Check oil level before each use and every 5 operating hours when engine is warm. Check oil level more frequently during engine break-in.
 - Keep oil at the upper limit on the dipstick (Figure 2 inset).
 - Be sure oil fill cap is tightened securely when checking.
1. Remove the oil fill cap and wipe the dipstick clean (Figure 2).
 2. Insert the oil fill cap into the oil fill neck and securely fasten.
 3. Loosen and remove the oil fill cap from the oil fill neck. Note the oil level, if oil reading on the dipstick is below the upper limit, slowly add oil to reach the upper limit (Figure 2 inset).
 4. Replace the oil fill cap into the oil fill neck and securely fasten before starting engine.

NOTE: Do not overfill. Overfilling with oil may cause smoking, hard starting, spark plug fouling, or oil saturation of air cleaner.

NOTE: To change the oil on your engine, see Oil Change on page 9.

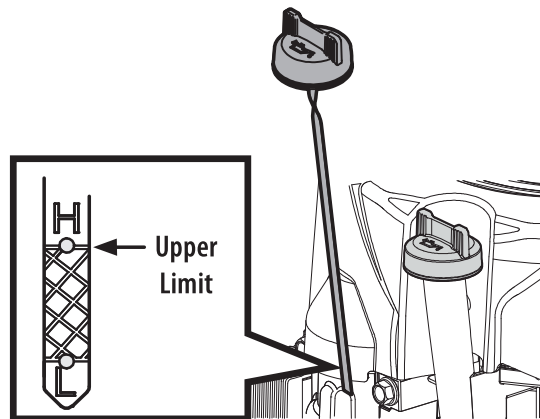

Figure 2

SET-UP

FUEL REQUIREMENTS

⚠ CAUTION

Operating the engine with E15 or E85 fuel, an oil/gasoline mixture, dirty gasoline, or **gasoline over 30 days old** without fuel stabilizing additive may result in damage to your engine's carburetor. Subsequent damage would **not** be covered under the manufacturer's warranty.

Use automotive gasoline (unleaded or low leaded to minimize combustion chamber deposits) with a minimum of 87 octane. Gasoline with up to 10% ethanol (E10) or 15% MTBE (Methyl Tertiary Butyl Ether) can be used. Never use an oil/gasoline mixture or dirty gasoline. Avoid getting dirt, dust, or water in the fuel tank. **DO NOT use E15 or E85 gasoline.**

⚠ WARNING

Gasoline is extremely flammable and is explosive under certain conditions.

- Refuel in a well-ventilated area with the engine off and allowed to cool. Do not smoke or allow flames or sparks in the area where the engine is refueled or where gasoline is stored.
- Do not overfill the fuel tank. After refueling, make sure the fuel cap is closed properly and securely.
- If fuel is spilled, wipe it off the engine and the equipment. Move equipment to another area and wait 5 minutes before starting the engine.
- Avoid repeated or prolonged contact with skin or breathing of vapor.

HIGH ALTITUDE OPERATION

At high altitude, the standard carburetor air-fuel mixture will be excessively rich causing decreased performance and increased fuel consumption. If this engine is operated at an altitude of 4000 ft. (1219 meters) or above, installation of a high altitude kit by an authorized dealer is required. Operating the engine with the wrong configuration at a given altitude may decrease fuel efficiency and performance.

ADDING FUEL

⚠ WARNING

An adult should fuel this engine. NEVER allow children to refuel the engine. Gasoline (fuel) vapors are highly flammable and can explode. Fuel vapors can spread and be ignited by a spark or flame many feet away from engine. To prevent injury or death from fuel fires, follow these instructions:

- DO NOT use leaded fuel.
- Fuel must be fresh and clean. NEVER use fuel left over from last season or stored for long periods.
- NEVER mix oil with fuel.
- DO NOT use fuel containing Methanol (Wood Alcohol).
- Fill fuel tank outdoors or in well ventilated area.

NOTE: Before refueling, allow engine to cool for at least 5 minutes.

1. Clean area around the fuel fill cap and remove the fuel cap.
2. Use an approved red GASOLINE container, add fuel slowly, being careful to avoid spilling. DO NOT overfill fuel tank.
3. Fill tank to full as indicated by the fuel level indicator inside the fuel tank if equipped or to no more than 1/2 inch below the bottom of the fill neck to allow space for fuel expansion.
4. Replace the fuel cap and tighten securely. Wipe up spilled fuel before starting engine. If fuel is spilled DO NOT start engine. Move machine away from area of spillage. Avoid creating any source of ignition until fuel vapors are gone.
5. Be sure fuel shut-off valve, if present, is in the "ON" position.

OPERATION

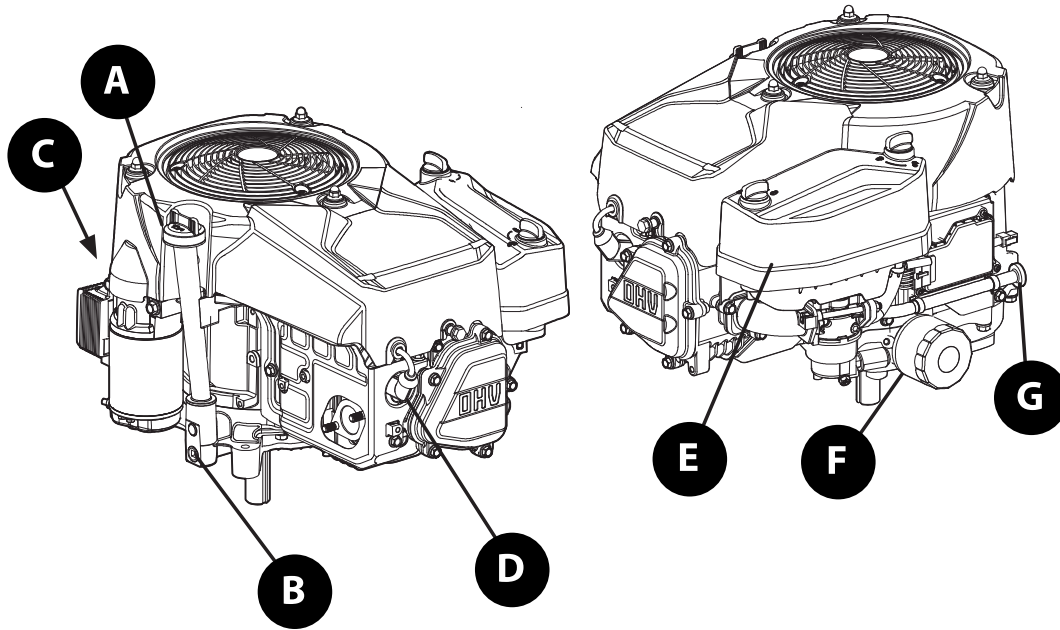

Figure 3

Features

A. OIL FILL CAP

Remove the oil fill cap to check the oil level and add oil

B. OIL DRAIN PLUG

Removing the oil drain plug will drain the oil from the engine. The engine is equipped with a side drain.

C. MODEL PLATE

The model plate provides the model number and serial number of the engine. Record this information in the area provided on the cover of this manual. This information will be necessary for proper technical support.

D. SPARK PLUG

Refer to Spark Plug Service on page 11.

E. AIR CLEANER

Refer to Air Filter Service on page 10.

F. OIL FILTER

Refer to Oil Filter Service on page 10.

G. FUEL FILTER

Refer to Fuel Filter Service on page 12.

H. FUEL CAP (NOT SHOWN)

Remove the fuel cap to add fuel. Refer to the equipment operator's manual shipped with product for fuel cap location.

I. THROTTLE/CHOKE CONTROL (NOT SHOWN)

The throttle/choke control is used to aid in starting/stopping the engine and adjusting engine speeds. Refer to the equipment operator's manual shipped with product for throttle/choke control location and operation.

OPERATION

Pre-Operation Check

The engine is shipped without fuel and with oil in the engine. See the Set-Up Section of this manual for instructions on adding fuel and checking oil.

Starting the Engine

1. Release all controls on the mower.
2. Move the gear shift lever into the neutral (N) position.
3. If starting a cold engine, place the throttle/choke control all the way forward, into the CHOKE position (Figure 4).

Note: Use of choke may not be necessary if the engine is warm or the air temperature is high.

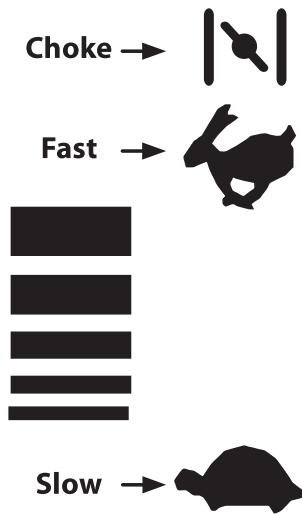

Figure 4

4. Insert the ignition key into the ignition switch.
5. Turn the ignition key clockwise to the START position. After the engine starts, release the ignition key. It will return to the RUN position (Figure 5).

⚠ CAUTION

DO NOT hold the ignition key in the START position for longer than 5 seconds at a time. Doing so may cause damage to your engine's electric starter.

6. Move the throttle/choke control into the FAST (rabbit) position.

NOTE: Never leave the throttle/choke control in the CHOKE while operating the mower. Doing so will result in a "rich" fuel mixture and cause the engine to run poorly.

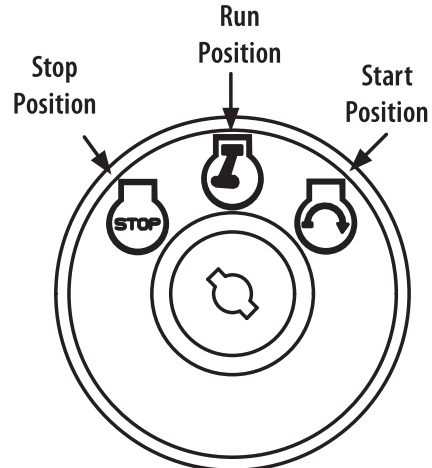

Figure 5

Stopping the Engine

⚠ WARNING

If you strike a foreign object, stop the engine and remove the ignition key (if so equipped). Thoroughly inspect the machine for any damage. Repair the damage before restarting and operating.

1. If the blades are engaged, disengage the PTO.
2. Turn the ignition key counterclockwise to the STOP position.
3. Remove the key from the ignition switch to prevent unintended starting.

SERVICE AND MAINTENANCE

⚠ WARNING

Shut off the engine before performing any maintenance. To prevent accidental start-up, remove safety key (if equipped), disconnect the spark plug wire and ground against the engine.

⚠ WARNING

If the engine has been running, the muffler will be very hot. Allow engine and muffler to cool before performing any maintenance.

General Recommendations

If engine must be tipped to transport equipment, inspect and remove grass, keep spark plug side of engine up. Transporting or tipping engine spark plug down may cause smoking, hard starting, spark plug fouling, or oil saturation of air cleaner.

Periodic inspection and adjustment of the engine is essential to maintaining engine performance and service life.

Required service intervals and maintenance are described in the table below. Follow the hourly or calendar intervals as listed. More frequent service is required when operating in adverse conditions.

Maintenance Schedule

Service	First 5 Hours	Each Use or Every 5-10 Hrs.	Every Season or 25 Hours	Every Season or 50 Hours	Every Season or 100 Hours	Service Dates
Check Engine Oil Level		✓				
Change Engine Oil *	✓			✓		
Change Engine Oil Filter*				✓		
Check Air Cleaner				✓		
Service Air Cleaner **					✓	
Check Spark Plug			✓			
Replace Spark Plug					✓	
Clean Cooling fins		✓				
Clean around Muffler and Finger Guard		✓				
Replace Fuel Filter					✓	

* Every season or 25 hours if operating under heavy load or high ambient temperature.

** Service more frequently when used in dusty areas.

Oil Service

- Check oil level regularly.
- Be sure correct oil level is maintained. Check every 5 hours or daily before starting engine. Checking Oil Level/Adding Oil on page 5.

OIL CHANGE

IMPORTANT: Be sure to check engine on a level surface with the engine stopped. Drain the oil while the engine is still warm to assure rapid and complete draining.

1. Remove all fuel from tank by running engine until it stops from lack of fuel.
2. Remove drain plug (a) and allow oil to drain into a suitable container (Figure 6).

SERVICE AND MAINTENANCE

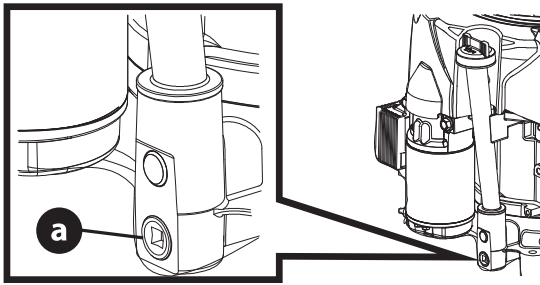

Figure 6

3. Reinstall the drain plug and tighten it securely, 12-14 Nm (106.2-123.9 in-lb).
4. Refill with the recommended oil and check the oil level. See Oil Recommendations and Checking Oil Level/Adding Oil on page 5.

IMPORTANT: Used motor oil may cause skin cancer if repeatedly left in contact with the skin for prolonged periods. Although this is unlikely unless you handle used oil on a daily basis, it is still advisable to thoroughly wash your hands with soap and water as soon as possible after handling used oil.

NOTE: Please dispose of used engine oil in a manner that is compatible with the environment. We suggest you take it in a sealed container to your local service station or auto parts store for recycling. Do not throw it in the trash or pour it on the ground.

OIL FILTER SERVICE

This engine is equipped with a spin-on oil filter that should be replaced each time an oil change is performed, every season or 50 hours (Figure 7).

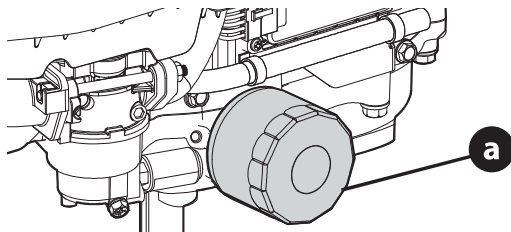

Figure 7

1. Drain oil. See STEPS 1-2 in Oil Change on page 9.
2. Remove oil filter (a). Dispose of old oil filter properly.
3. Lube gasket of new oil filter with clean oil.
4. Install and turn oil filter by hand until the gasket comes in contact with the sealing surface of the crankcase cover, then tighten the oil filter, 10-12 Nm (88.5-106.2 in-lb), 1/2-3/4 turn.
5. Reinstall the drain plug and tighten it securely, 12-14 Nm (106.2-123.9 in-lb).

6. Refill with the recommended oil and check the oil level. See Oil Recommendations and Checking Oil Level/Adding Oil on page 5.
7. Start and run engine. Check for leaks.
8. Stop engine. Wait a few minutes and check the oil level. See Checking Oil Level/Adding Oil on page 5.

Air Filter Service

Paper filters cannot be cleaned and should be replaced every 100 operating hours; more often if used in extremely dusty conditions.

⚠ WARNING

Never use gasoline or low flash point solvents for cleaning the air filter element. A fire or explosion could result.

IMPORTANT: Never run the engine without the air filter. Rapid engine wear will result.

1. Unscrew a 1/4 turn and remove the thumb screws.
2. Remove the air filter cover (Figure 8).

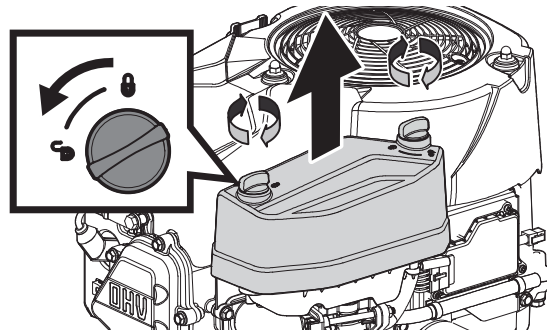

Figure 8

3. Pull up on an angle and then forward to remove the air filter (Figure 9).

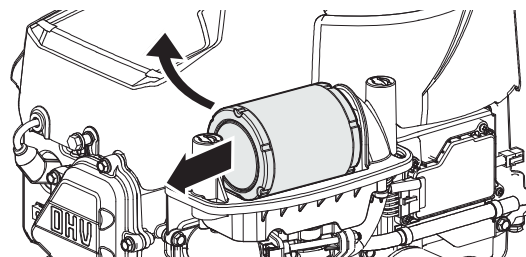

Figure 9

4. Remove the foam pre-filter (a) from around the paper air filter (b) (Figure 10). Replace paper element when dirty or damaged. Clean foam element or replace when damaged.

NOTE: The foam element cannot be purchased separately. Air filter is only sold as an assembly.

SERVICE AND MAINTENANCE

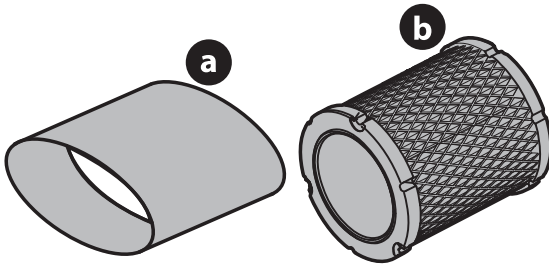

Figure 10

5. To clean foam element, wash in a mild liquid detergent and water. Squeeze or press the foam element to rinse out dirt and water. Do not twist; this could damage or tear the foam element. Allow to dry thoroughly before using. **DO NOT** oil the foam element.
6. Attach the new air filter with foam element, aligning the hole in the air filter with the intake manifold (Figure 11).

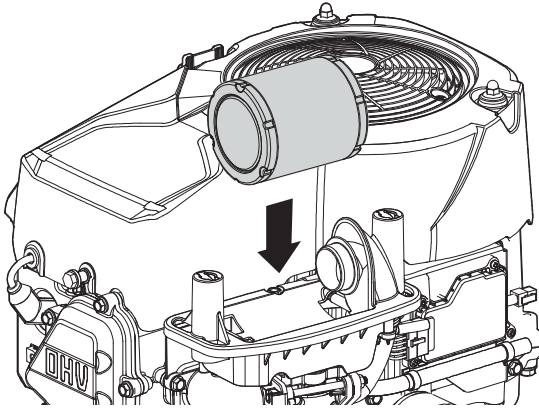

Figure 11

7. Attach the air filter cover (Figure 12). Turn thumb screws clockwise a 1/4 turn until snug. Check for any misalignment.

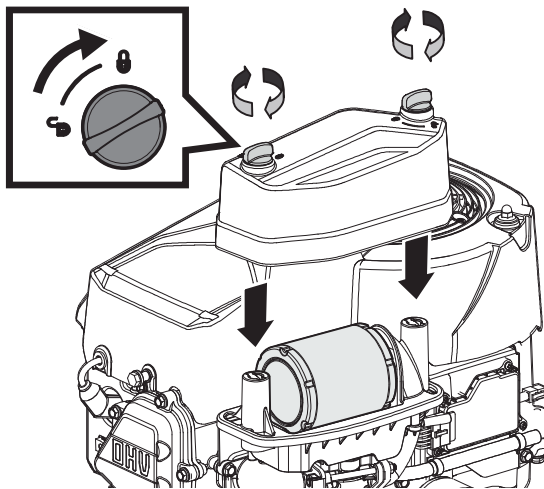

Figure 12

Spark Plug Service

⚠ WARNING

If the engine has been running, the muffler will be very hot. Allow engine and muffler to cool before performing any maintenance.

⚠ WARNING

DO NOT check for spark with spark plug removed. **DO NOT** crank engine with spark plug removed.

To ensure proper engine operation, the spark plug must be properly gapped and free of deposits.

1. Remove the spark plug boot (a) and use a spark plug wrench to remove the spark plug (b) (Figure 13).

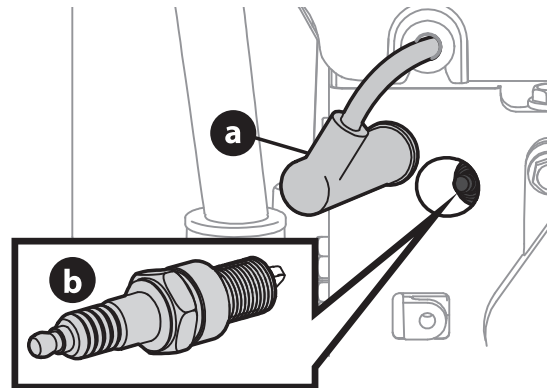

Figure 13

2. Visually inspect the spark plug. Discard the spark plug if there is apparent wear, or if the insulator is cracked or chipped. Clean the spark plug with a wire brush if it is to be reused.
3. Measure the plug gap with a feeler gauge. Correct as necessary by bending side electrode (c) (Figure 14). The gap should be set to 0.024 - 0.031 in.

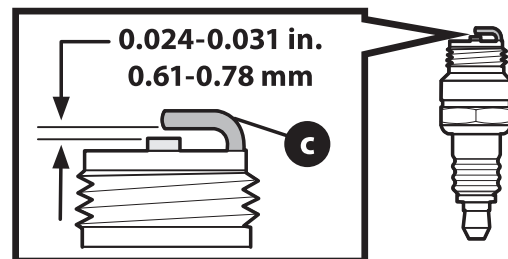

Figure 14

SERVICE AND MAINTENANCE

4. Check that the spark plug washer is in good condition and thread the spark plug in by hand to prevent cross-threading.
5. After the spark plug is seated, tighten with a spark plug wrench to compress the washer.

NOTE: When installing a new spark plug, tighten 1/2 turn after the spark plug seats to compress the washer. When reinstalling a used spark plug, tighten 1/8-1/4 turn after the spark plug seats to compress the washer.

IMPORTANT: The spark plug must be securely tightened. An improperly tightened spark plug can become very hot and may damage the engine.

Fuel Filter Service

The fuel filter cannot be cleaned and must be replaced once a year or every 100 operating hours; more often if run with old gasoline.

1. Remove all fuel from tank by running engine until it stops from lack of fuel.
2. Use pliers to squeeze tabs (a) on the clamps (b), then slide the clamps away from the fuel filter (c) (Figure 15).

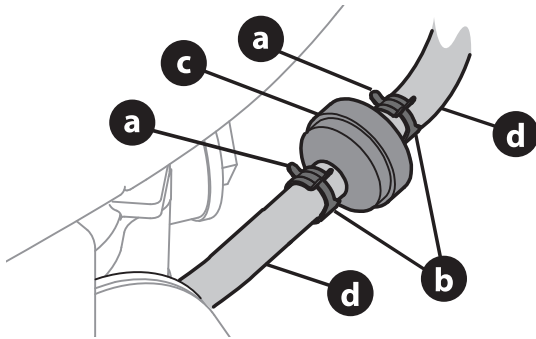

Figure 15

3. Twist and pull the fuel lines (d) off of the fuel filter.
4. Replace with a new fuel filter.
5. Secure the fuel lines with the clamps.

Clean Engine

If the engine has been running, allow it to cool for at least half an hour before cleaning. Periodically remove dirt build-up from engine. Clean cooling fins every 25 hours. Clean with a brush or compressed air.

IMPORTANT: Do not spray engine with water to clean because water could contaminate fuel. Using a garden hose or pressure washing equipment can also force water into the air cleaner or muffler opening. Water in the air cleaner will soak the paper element, and water that passes through the element or muffler can enter the cylinder, causing damage.

⚠ WARNING

Accumulation of debris around muffler could cause a fire. Inspect and clean before every use

Storage

⚠ CAUTION

Failure to use a fuel stabilizing additive or completely run the engine until it's out of fuel before off-season storage may result in damage to your engine's carburetor. Subsequent damage would **not** be covered under the manufacturer's warranty.

Gasoline that will be stored longer than 30 days needs to be pre-treated upon purchase with fuel stabilizer to prevent gum and varnish from forming in the engine's fuel and intake system. Improper fuel storage can result in hard starting, no starting, stalling and poor performance. If the gasoline in your engine deteriorates during storage, you may need to have the carburetor, and other fuel system components, serviced or replaced.

1. The fuel tank should be at least 95% filled with fuel. A full fuel tank reduces condensation build up.

⚠ WARNING

Never leave engine unattended while running.

2. Change oil. See Oil Change section.
3. Remove spark plug and pour about 1/2 an ounce of engine oil into cylinder. Replace spark plug and crank slowly to distribute oil.
4. Clean debris from around engine, under finger guard, and under, around and behind muffler. Touch up any damaged paint, and coat other areas that may rust with a light film of oil.
5. Store in a clean, dry and well ventilated area away from any appliance that operates with a flame or pilot light, such as a furnace, water heater, or clothes dryer. Also avoid any area with a spark producing electric motor, or where power tools are operated.
6. If possible, also avoid storage areas with high humidity, because that promotes rust and corrosion.
7. Keep the engine level in storage. Tilting can cause fuel or oil leakage.



Removing From Storage

1. Check your engine as described in the Pre-Operation Check section of this manual.
2. If the fuel was drained during storage preparation, fill the tank with fresh gasoline. If you keep a container of gasoline for refueling, make certain it contains only fresh fuel. Gasoline oxidizes and deteriorates over time, causing hard starting.
3. If the cylinder was coated with oil during storage preparation, the engine will smoke briefly at startup. This is normal.

TROUBLESHOOTING

Problem	Cause	Remedy
Engine Fails to start	<ol style="list-style-type: none"> 1. Choke not activated. 2. Spark plug boot disconnected. 3. Fuel tank empty or stale fuel. 4. Faulty spark plug. 5. Reduced fuel flow/Blocked fuel filter. 6. Engine flooded. 7. Dead battery. 8. Blown fuse. 	<ol style="list-style-type: none"> 1. Place throttle/choke control in CHOKE position. 2. Connect wire to spark boot. 3. Use fuel siphon to drain fuel tank. Fill tank with clean, fresh gasoline. 4. Clean, adjust gap, or replace. 5. Use fuel siphon to Drain fuel tank. Replace fuel filter as instructed in the Maintenance section. 6. Crank engine with throttle in FAST position. 7. Recharge battery. See equipment operator's manual. 8. Replace blown fuse. See equipment operator's manual.
Engine runs erratic	<ol style="list-style-type: none"> 1. Spark plug boot loose. 2. Reduced fuel flow/Blocked fuel filter. 3. Vent in gas cap plugged. 4. Water or dirt in fuel system. 5. Dirty air cleaner. 6. Engine running with CHOKE activated. 	<ol style="list-style-type: none"> 1. Connect and tighten spark plug boot. 2. If necessary, use fuel siphon to drain fuel tank. Replace fuel filter as instructed in the Maintenance section. 3. Clear vent. 4. If necessary, use fuel siphon to drain fuel tank. Drain fuel tank. Refill with fresh fuel. 5. Replace air cleaner element and/or clean pre-cleaner. 6. Move throttle/choke control out of CHOKE position.
Engine overheats	<ol style="list-style-type: none"> 1. Engine oil level low. 2. Air flow restricted. 	<ol style="list-style-type: none"> 1. Fill crankcase with proper oil. 2. Clean grass clippings and debris from around the engine's cooling fins and blower housing.
Occasional skips (hesitates) at high speed	<ol style="list-style-type: none"> 1. Spark plug gap too close. 	<ol style="list-style-type: none"> 1. Remove spark plug and adjust gap.
Idles poorly	<ol style="list-style-type: none"> 1. Spark plug fouled, faulty, or gap too wide. 2. Dirty air cleaner. 	<ol style="list-style-type: none"> 1. Reset gap or replace spark plug. 2. Replace air cleaner element and/or clean pre-cleaner.

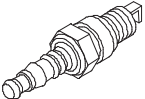
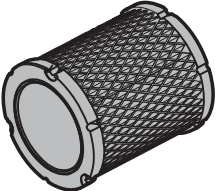
**REPLACEMENT PARTS • (SP) PLEZAS DE REEMPLAZO
• (FR) PIÈCES DE RECHANGE**

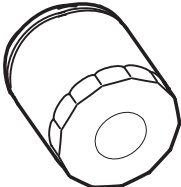
Component Piezas Pièces	Part Number and Description Piezas de Reemplazo Pièces de rechange	
	951-10292	Spark Plug Bujía bougie d'allumage
	937-05066	Air Filter Assembly (Includes Pre-Filter) Depurador de aire (incluye prefiltro) filtre à aire (comprend un préfiltre)
	951-3013	Fuel Filter Filtro de combustible filtre à carburant
	951-12690	Oil Filter Filtro de aceite Filtre d'huile