

LET'S GET STARTED

1. UNPACK YOUR NEW PC

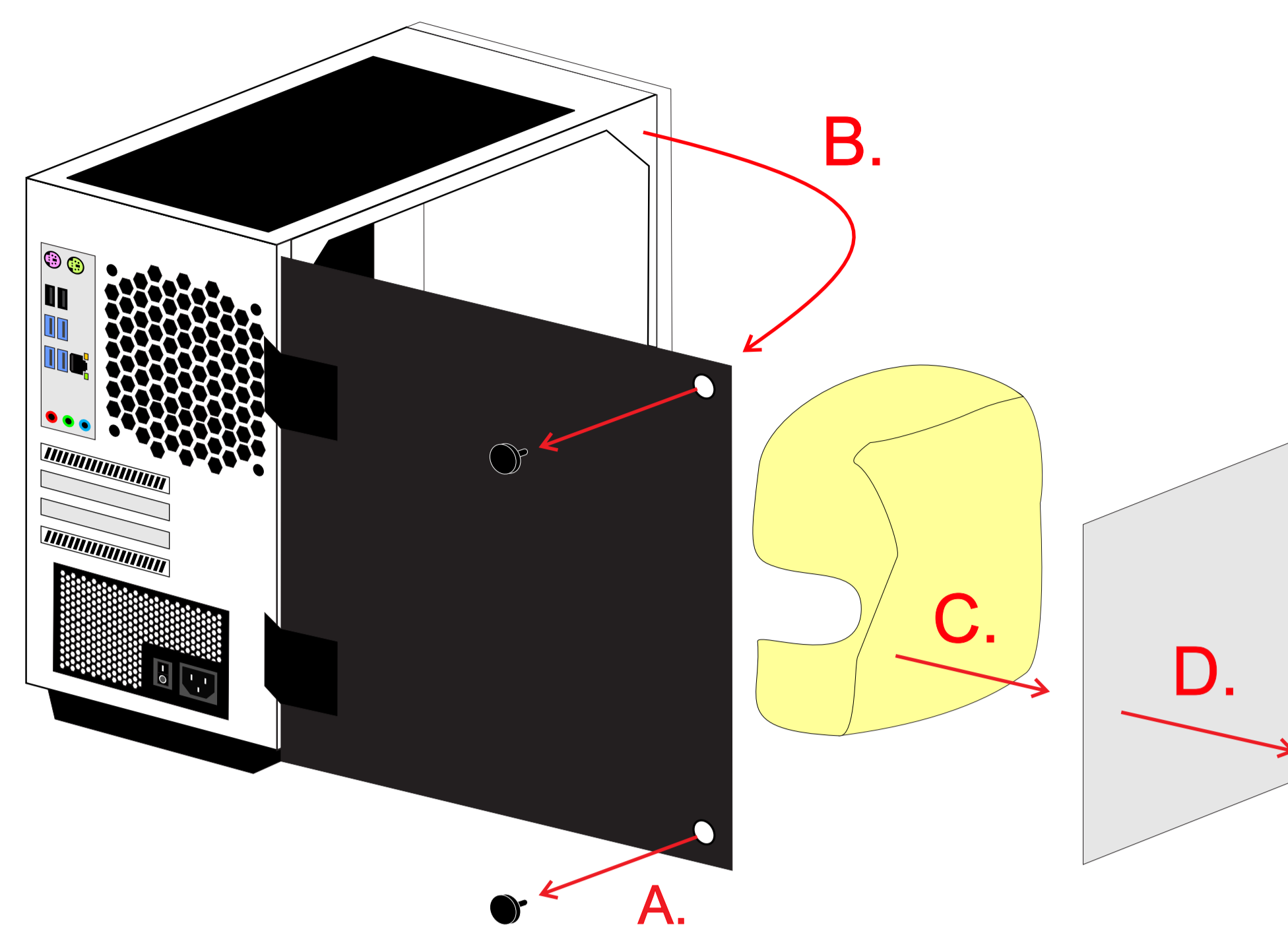

- A. Unscrew the Thumbscrews to release the glass panel.
- B. Swing the panel outward.
- C. Remove the info sheet covering the protective foam.
- D. Remove the protective foam from the inside of the PC (carefully as to not dislodge any wires).

2. CONNECT PERIPHERALS

Keyboard Mouse

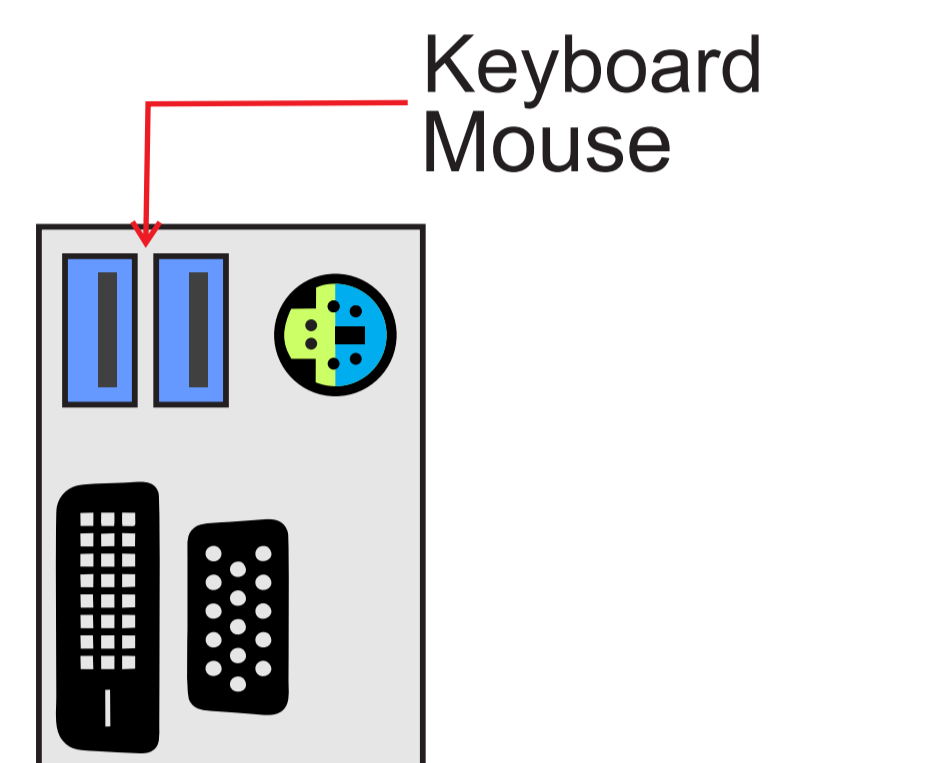

Connect Antennas
Some of our PCs Have WiFi cards. If you see two gold connectors on the back of your PC, please attach the two included antennas.

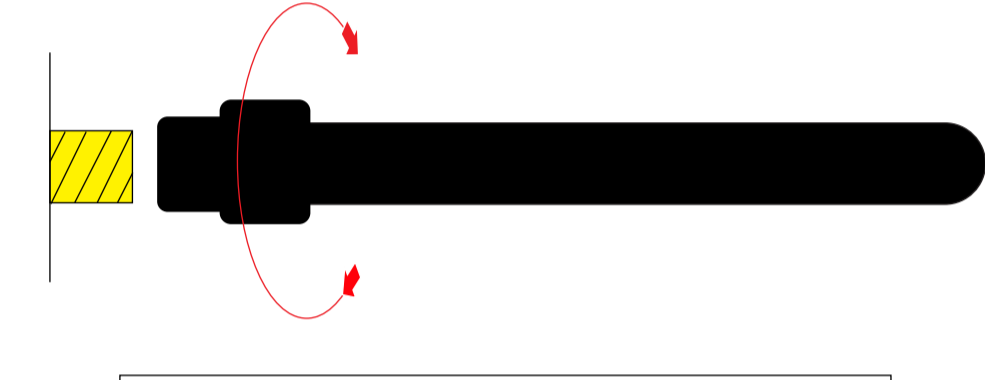

USB Port Types

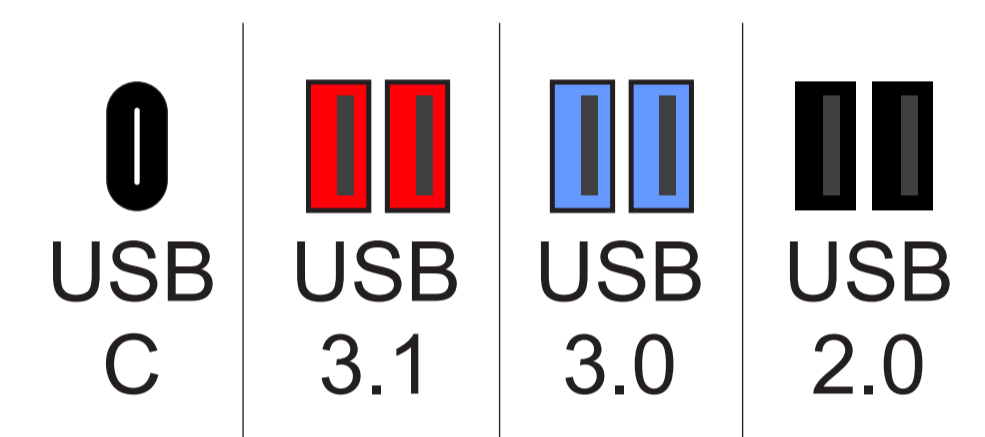

USB ports may differ by model

Internet

Mic In (Red)
Audio Out (Green)
Line In (Blue)

3. CONNECT YOUR MONITOR

STOP Do not plug your monitor into the onboard graphics port, It is disabled when a graphics card is installed.

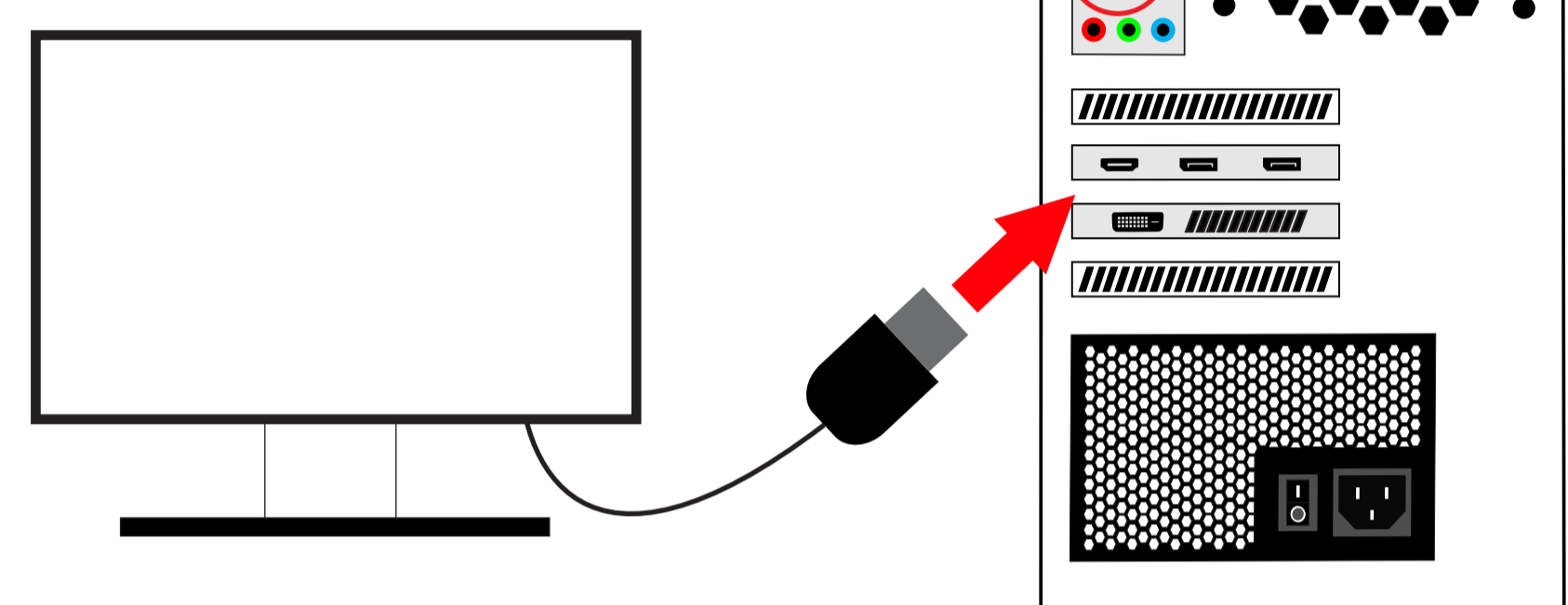

Supported Connections
Only one is needed. Placement may differ.

- HDMI
- Display Port
- DVI not available on all cards.

Please be aware that with newer graphics cards VGA is not supported. If your monitor is VGA, you will need to purchase a "ACTIVE VGA TO HDMI ADAPTER".

4. CONNECT THE POWER CABLE

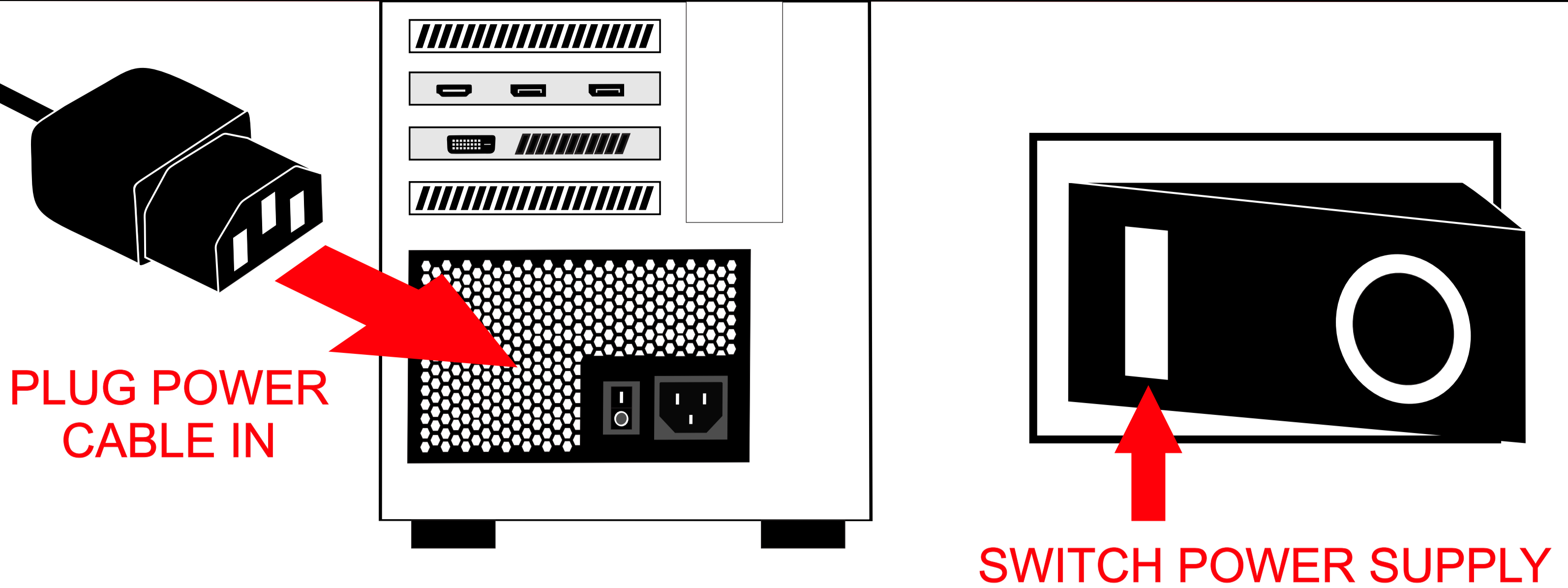

PLUG POWER CABLE IN

SWITCH POWER SUPPLY TO THE ON POSITION

5. POWER ON YOUR NEW PC

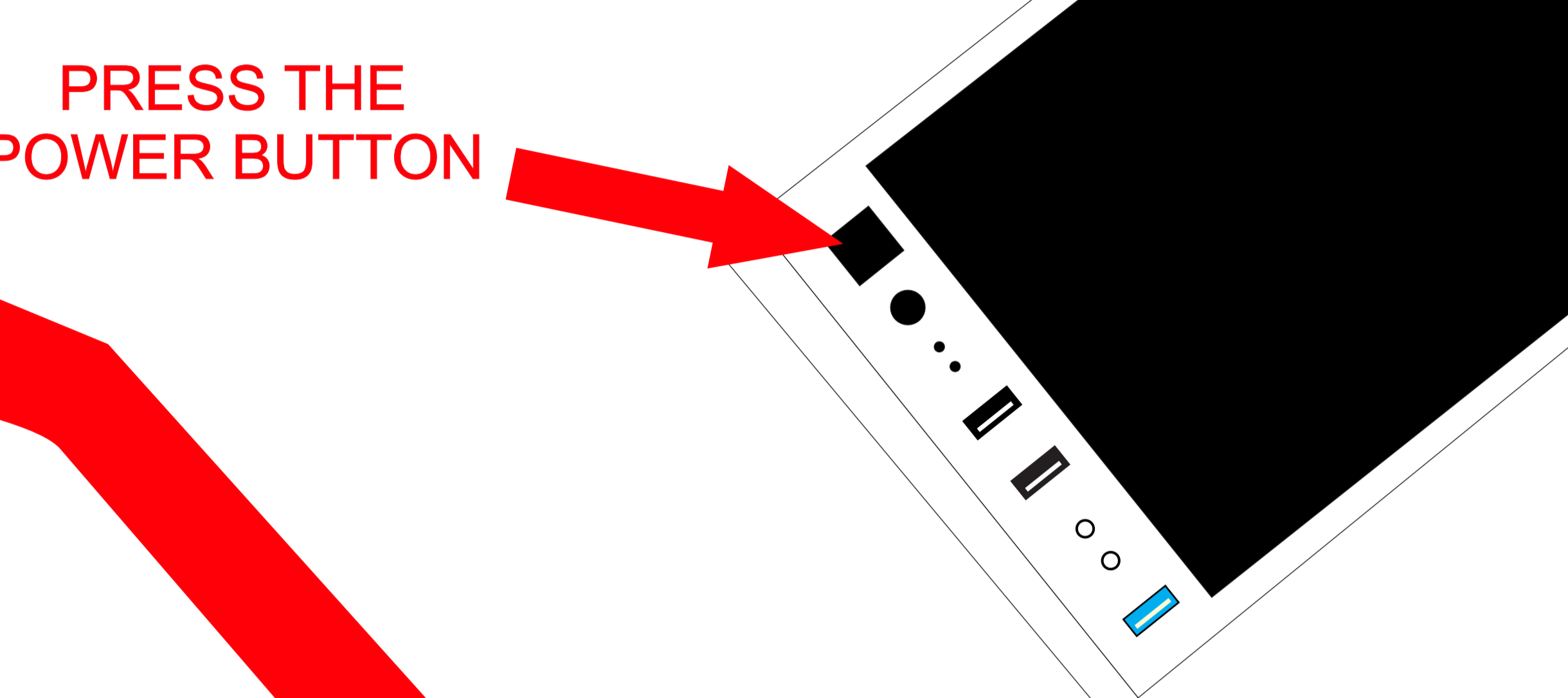

PRESS THE POWER BUTTON

Please do not power off your PC during the initial setup process.

6. FINISH!

WAIT FOR WINDOWS TO LOAD
Follow the on-screen instruction to complete your installation, setup your login, and configure your privacy settings.

Do your computers come fully built?

Your PC comes fully assembled and ready to use. Just follow the instructions in this guide to get up and running.

What is included with my PC?

Every PC comes with a Quick Start Guide, Maintenance Guide, Quality Certificate, Troubleshooting Guide, Power Cable, Mouse, Keyboard, and any system specific accessories provided by the manufacturer.

Where can I find my Windows Activation Key?

Microsoft no longer provides stickers with your product key to system integrators. Your PC comes fully activated and the product key is registered to your PC's motherboard. If your PC is for some reason not showing that it is activated please contact our Customer Support Team and we will be happy to get your activation key for you.

My order has the wrong / missing component / accessory.

Please contact our Customer Support Team and we will be happy to get your issue resolved.

What is the bundle of unplugged cables inside my PC?

You do not need to touch those as they are extra cables. We try to bundle them away as neatly as possible. These cables are not necessary for the PC to work properly.

How do I change the color of the RGBs on my fans / case?

If your PC comes with RGB Lighting / RGB fans, please refer to the RGB guide at www.skytechgaming.com/rgb for the proper way to adjust them. If you still need assistance, please contact our Customer Support Team.

Can I Overclock my PC?

While we offer factory overclocking services, we do not support any overclocking done by our customers. Issues that may arise or damage explicitly caused to components by customer overclocking may not be covered under your warranty. Overclock at your own risk.

QUICK START GUIDE



SKYTECH GAMING

USA (888) 370-8882

www.skytechgaming.com

support@skytechgaming.com

Monday - Friday 9:00am - 6:00pm PST

FREQUENTLY
ASKED
QUESTIONS

Design
Assembly
Support
Repair



READ THIS FIRST

GM